

STORZKOPPELINGEN

koppelingen, systeem Storz - aluminium / messing Aluminium or brass Storzcouplings



Symetrische koppelingen volgens het bajonetsysteem welke geschikt zijn voor zuigen en persen en voorzien van perbunan afdichtingsringen.

Maximale werkdruk t/m NW050 - 25 bar.

Maximale werkdruk van NW050 t/m NW150 - 16 bar.

Storzcouplings with Perbunan seal, suitable for suction and discharge.

Maximum workingpressure up to NW050 = 25 bar
From NW050 up to NW150 = 16 bar

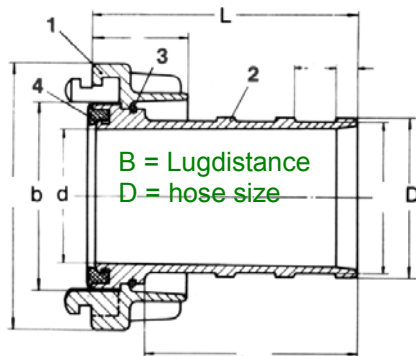

Nokafstand Lugdistance	Slangpilaar Size pillar	Aluminium Part-no:	Brass Part-no:
31 mm	19 mm	FK031019	HK031019
31 mm	25 mm	FK031025	HK031025
44 mm	32 mm	FK044032	HK044032
52 mm	25 mm	FK052025	HK052025
52 mm	32 mm	FK052032	HK052032
52 mm	38 mm	FK052038	HK052038
66 mm	25 mm	FK066025	HK066025
66 mm	32 mm	FK066032	HK066032
66 mm	38 mm	FK066038	HK066038
66 mm	50 mm	FK066050	HK066050
81 mm	38 mm	FK081038	HK081038
81 mm	50 mm	FK081050	HK081050
81 mm	65 mm	FK081065	HK081065
81 mm	75 mm	FK081075	HK081075
89 mm	65 mm	FK089065	HK089065
89 mm	75 mm	FK089075	HK089075
115 mm	100 mm	FK115100	HK115100
133 mm	100 mm	FK133100	HK133100
188 mm	150 mm	FK188150	-



Storzringen Rubber Storzseals

Artikelno: Part-no:

031 mm	FR031
044 mm	FR044
052 mm	FR052
066 mm	FR066
081 mm	FR081
089 mm	FR089
115 mm	FR115
133 mm	FR133

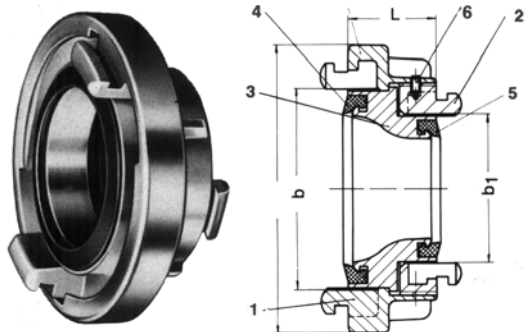

L.M.Storzverloopkoppelingen Aluminium Storz reducers

Artikelno: Part-no:

066 mm x 052 mm	FV066052
081 mm x 066 mm	FV081066
089 mm x 066 mm	FV089066
089 mm x 081 mm	FV089081
115 mm x 089 mm	FV115089
133 mm x 089 mm	FV133089
133 mm x 115 mm	FV133115

See document Eth-051 for Storzadaptors male & female BSP thread and Caps